

# New Acute Care Hospital and Skilled Nursing Facility

San Francisco, CA



## Thesis Proposal

Tim Ariosto – Structural Option

Faculty Advisor - Dr. Richard Behr  
January 13, 2010

## Executive Summary

The New Acute Care Hospital and Skilled Nursing Facility is an addition to the existing Chinese Hospital complex located in San Francisco, CA. The 7 story structure has been designed using a concrete slab on steel framing with a special moment frame lateral system.

In Technical Report 3, seismic loads were found to be the controlling load condition for both strength and serviceability. Since structures tend to deform beyond their elastic limits during major seismic events, fluid viscous dampers (FVD) will be investigated to determine a configuration which will be most efficient at absorbing and dissipating transient forces. The four configurations which will be studied are

- FVDs on diagonal braces
- FVDs on diagonals of concentric chevrons
- FVDs located horizontally on concentric chevrons
- FVDs incorporated into a toggle brace damper system.

Once the FVD configuration which best limits drift and flexural rotation of connections has been determined, the existing lateral system members will be redesigned using smaller sections where appropriate.

In addition to this structural depth, two non-structural breadths will be undertaken. A cost and schedule analysis will be used to compare the effect of the FVD design to the original design in terms of time and economy. An architectural breadth will be undertaken to investigate the effects (both to the exterior façade and to interior rooms) of adding braces with FVDs to selected moment frames throughout the structure.

## Table of Contents

Executive Summary.....	2
Table of Figures.....	4
Introduction .....	5
Existing Structure Overview.....	6
Foundation System .....	6
Framing System.....	6
Floor System .....	9
Lateral System.....	9
Roof System .....	10
Other Features .....	10
Applicable Codes.....	11
Original Design Codes Used .....	11
Design Codes Used in Thesis Analysis.....	11
Problem Statement.....	12
Proposed Solution.....	12
Breadth Topics .....	15
Construction.....	15
Architectural .....	15
Methods.....	15
Tasks.....	16
Timetable .....	17
Conclusions .....	18
APPENDIX .....	19
Appendix A: References.....	20

## Table of Figures

Figure 1: Site View of New Acute Care Hospital (blue) located adjacent to existing Chinese Hospital. Photo Courtesy of Google Maps. ....	5
Figure 2: Exterior view of New Acute Care Hospital and surrounding buildings .....	5
Figure 3: Typical Framing Plan with columns highlighted .....	7
Figure 4: Typical Framing Plans with lateral system highlighted in blue.....	8
Figure 5: Reduced Beam Section .....	9
Figure 6: Parallel beams used for plumbing .....	10
Figure 7: Diagonal Brace FVD Configuration.....	13
Figure 8: Diagonal FVD's on Chevrons .....	13
Figure 9: Horizontal FVDs on Chevrons .....	14
Figure 10: Toggle-Brace Damper System.....	14

## Introduction

The New Acute Care Hospital and Skilled Nursing Facility will serve as an addition to the existing Chinese Hospital located in the historic Chinatown district of San Francisco (See Fig. 1). The site lies on the north flank of Nob Hill, at an elevation of approximately 110' above sea level. Due to the slope of the site, the ground floor of the site is located partially below grade.

This new addition will be connected directly to the existing Chinese Hospital, located at 845 Jackson Street. As part of the construction of this addition, the original portion of the hospital built in 1925 will be demolished. Then the new facility, which has seven stories above ground and one below will be constructed with a hard connection to a previous addition built in 1975. Therefore, the precast concrete panel exterior façade has been designed in a way that respects the 1975 design while providing a more modern look.

At approximately 92,000 SF, this new facility will provide additional patient rooms as well as well several new medical departments to serve the local community. Construction is expected to begin in 2010 and reach completion by Chinese New Year 2013.



Figure 1: Site View of New Acute Care Hospital (blue) located adjacent to existing Chinese Hospital. Photo Courtesy of Google Maps.



Figure 2: Exterior view of New Acute Care Hospital and surrounding buildings

## Existing Structure Overview

The structure of the New Acute Care hospital rests on a mat foundation and consists primarily of composite steel decking with steel framing. A perimeter moment frame system is used to resist lateral loading.

## Foundation System

According to the geotechnical report provided by Treadwell & Rollo, the soil conditions on the site can be described as “very stiff to hard sandy clay and clay with gravel,” which rests on “intensely fractured, low hardness, weak, deeply weathered shale.” Because of this, the New Acute Care Facility has been designed to bear on a 36” mat foundation. Columns rest on concrete pedestals, typically sized at 3’-0” x 3’-0”. Since the base of the structure will lie below the water table, the foundation was also designed for hydrostatic uplift.

The close proximity to nearby structures (see Figure 2), particularly the 1975 addition to the Chinese Hospital, provided a challenge to the designers. Underpinning was used to maintain the foundations of existing structures on either side of the building.

## Framing System

The New Acute Care Hospital uses steel columns (See Figure 3) to support the buildings gravity loads. These columns range in size from W14x445 near the base of the structure to W8x40’s near the roof level. As the columns rise vertically through the structure they are spliced together, usually at a distance of 22’-0”. Aside from those used in the lateral system, most of the columns are connected to beams and girders using pinned connections.





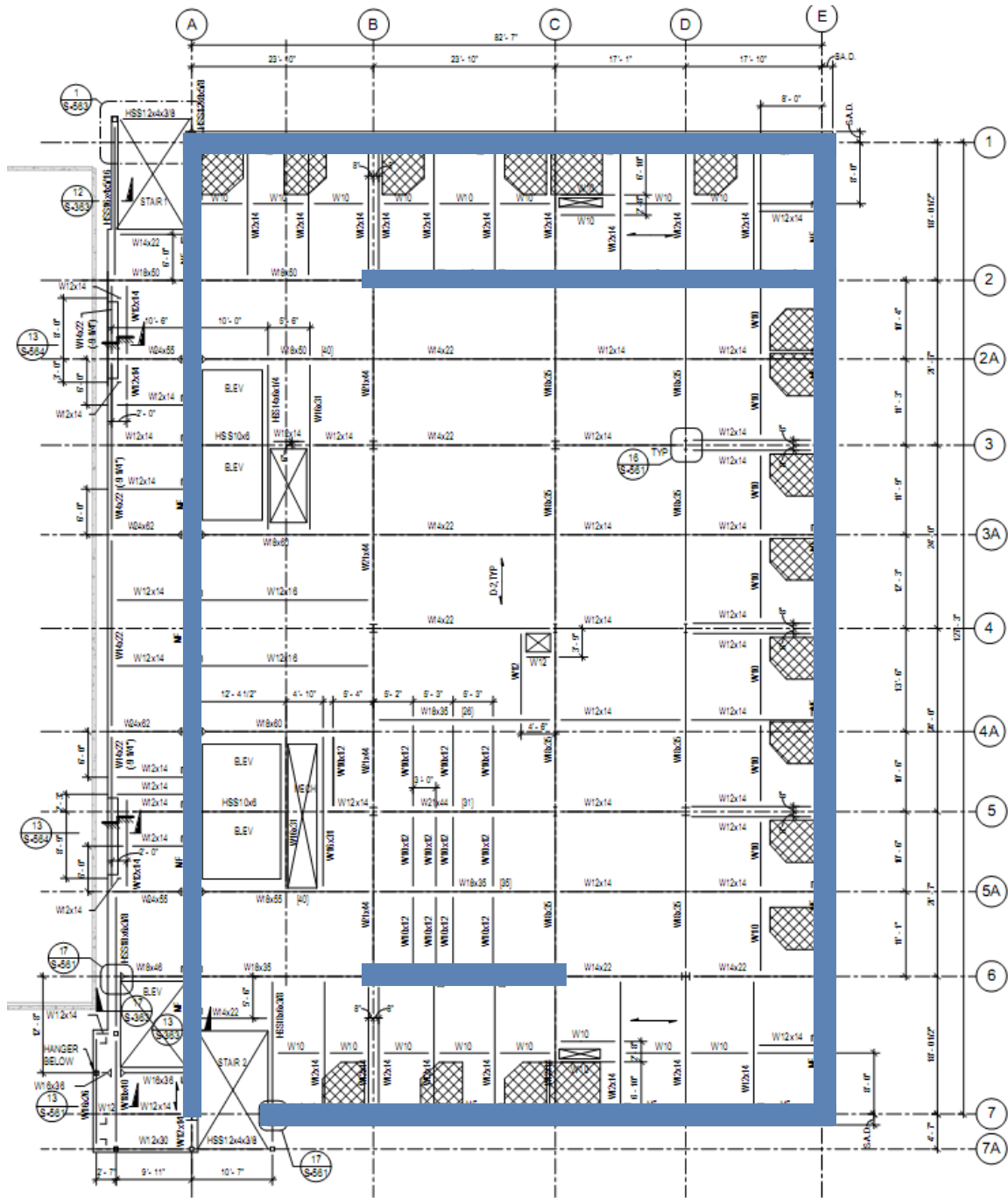

Figure 4: Typical Framing Plans with lateral system highlighted in blue



## Floor System

The floor system consists of a composite floor system using a 3" Verco W3 Formlock deck with an additional 3 ¼" of concrete resulting in a total thickness of 6 ¼". This slab then rests on W-shapes ranging from W10x12's used as beams to sizes as large as W24x207's which also serve in the buildings lateral system. ¾" Ø shear studs were used to achieve composite action.

There are several different bay sizes used in the New Acute Care Hospital. Larger bay typically exist towards the plan east side of the building while smaller bay sizes are typically used in the western portion of the structure. In most cases, the bays varied from approximately 18'-0"x 17'-0" to 23'-10"x24'-0".

## Lateral System

Lateral loads are transmitted through the structure primarily through the use of a series of special moment frames. There are 4 special moment frames running east-west, and 2 running north-south. One of the EW frames, located along gridline 2, terminates at the third floor level.

Since brittle failure of connections in moment frames tends to be a problem in regions of high seismic activity, the moment frame beams have been designed using Reduced Beam Sections (RBS). These RBS sections help to insure that yielding occurs in the reduced section of the beam rather than in the connection itself. See Figure 5 below.

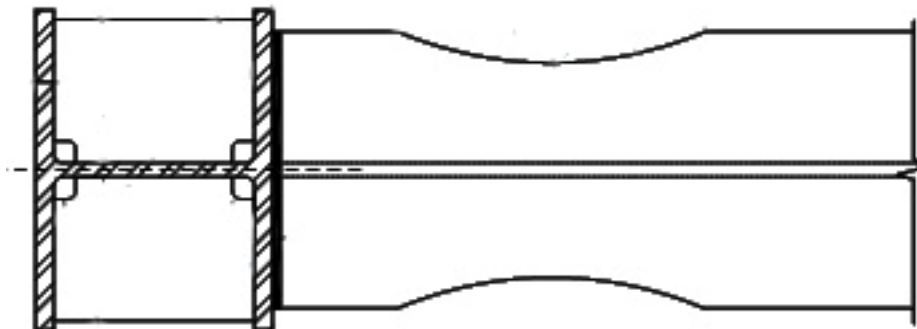

Figure 5: Reduced Beam Section

In addition to the steel moment frames, the basement walls also serve as shear walls for the basement level. These walls are 18" thick and composed of 4ksi concrete.

## Roof System

The roof system is supported in a similar manner to the floors below, with a concrete filled metal deck supported by beams and girders. However, beams at this level are typically spaced much closer together, at a distance of approximately 10-12 feet. The sizes of these roof beams generally vary from W10x12's to W24x104's.

## Other Features

One of the unique structural features of the New Acute Care Hospital is its connection to the existing Chinese Hospital. The structures are connected with a seismic gap that allows the two structures to act independently. This size of this gap varies with story height so that a greater amount of movement is allowed at the upper floors.

A second unique feature of the New Acute Care Hospital is a result of the tight floor plan. There are several areas in which partition walls lie directly on beams. Since plumbing would normally be routed through these partition walls, a system of two, parallel beams spaced at 16" were used to create a gap for the plumbing system. See Figure 6 below.

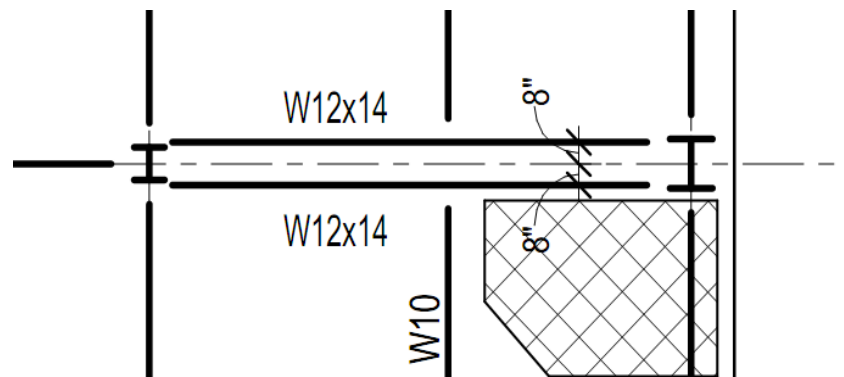

Figure 6: Parallel beams used for plumbing

## Applicable Codes

### Original Design Codes Used

In addition to the following codes, the California State Government requires that all new government and hospital buildings are approved by the Office of Statewide Health Planning and Development (OSHPD).

- 2007 California Administration Code
  - Part 1, Title 24, CCR
- 2001 California Building Code
  - Part 2, Title 24, CCR
  - (1997 UBC and 2001 CA Amendments)
- 2004 California Electrical Code
  - Part 3, Title 24, CCR
  - (2002 NEC and 2004 CA Amendments)
- 2001 California Fire Code
  - Part 4, Title 24, CCR
  - (2000 UMC and 2001 Amendments)

### Design Codes Used in Thesis Analysis

- American Society of Civil Engineers (ASCE)
  - ASCE7-05, Minimum Design Loads for Buildings and Other Structures
- International Building Code, 2006 Edition
- American Institute of Steel Construction (AISC)
  - Steel Construction Manual, Thirteenth Edition (LRFD)
- American Concrete Institute
  - ACI 318-08, Building Code Requirements for Structural Concrete

## Problem Statement

In Technical Report 3, seismic loads were found to be the controlling load condition for the structure of the New Acute Care Hospital. Seismic Loads, in comparison to wind loads, are generally considered to be a primarily a strength issue, rather than a strength and serviceability issue. This presents a unique challenge to structures controlled by seismic loads. While it is of primary importance that the structure survives the seismic event long enough for the buildings occupants to get to safety, it is also important that the structure can still be used afterwards. One means by which this can be accomplished is through the use of Fluid Viscous Dampeners.

## Proposed Solution

When major seismic events occur, structural elements tend to deform beyond their elastic limits, which can potentially result in failure or collapse of these individual elements. Fluid Viscous Dampers (FVDs), which absorb energy from sudden jerks and movements, work like shock absorbers in a car. When applied as a supplement to a structure, they can be designed to absorb and dissipate the energy from a major seismic event; thus protecting the rest of the structure.

The purpose of this thesis investigation will be to determine how Fluid Viscous Dampers can be most efficiently incorporated into the existing structural system. A comparison will be made of several different FVD brace configurations and locations on moment frames. The configurations that will be investigated are dampers on diagonal braces (See Figure 7); concentrically braced chevrons with dampers on diagonals (See Figure 8), concentrically braced chevrons with horizontal dampers (See Figure 9) and a toggle brace damper system (See Figure 10). A Time History Analysis will be undertaken using ETABs to determine the best overall configuration. The criterion for this comparison will be overall drift and the flexural rotation of connection elements, as well as component cost.

Since these dampers will serve to increase the amount of seismic load that the structure can take, an investigation will also be undertaken to determine whether any reduction in size of the existing lateral system is possible.



Figure 7: Diagonal Brace FVD Configuration

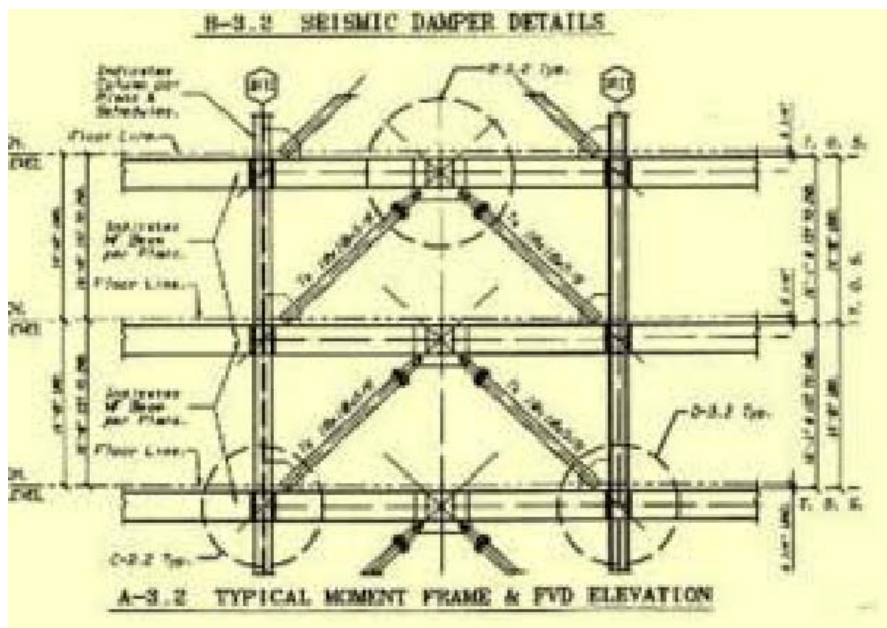

Figure 8: Diagonal FVD's on Chevrons



Figure 9: Horizontal FVDs on Chevrons

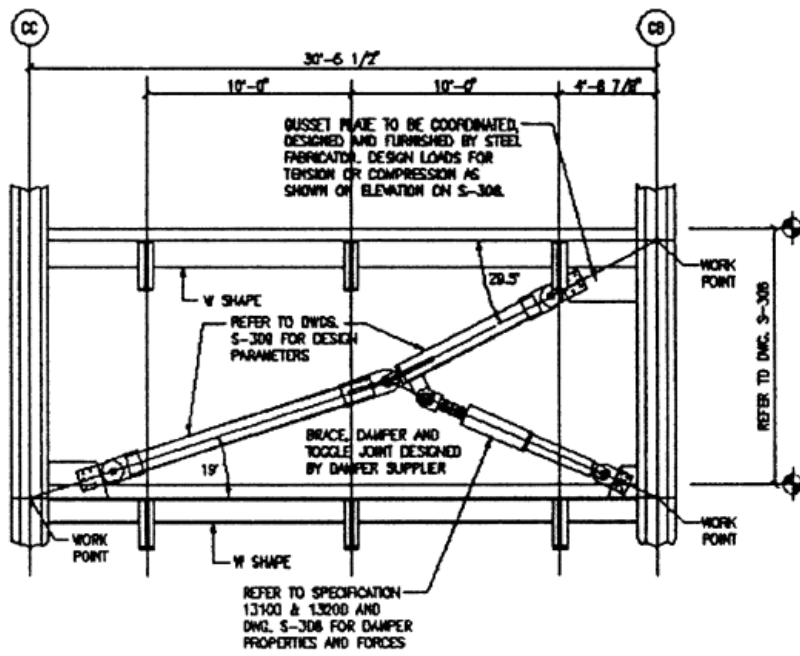

Figure 10: Toggle-Brace Damper System

## Breadth Topics

### Construction

Due to the addition of FVDs and the redesign of the lateral system; a cost and schedule impact will also be undertaken to determine the effects of the changes. Included in this breadth will be estimates on the prices of FVDs as well as installation costs for the new system. The price of the FVDs will then be compared with the cost reduction of reducing the size of the lateral system. Since the expected completion date of Chinese New Year 2013 is important symbolically to the project, it will be important to determine whether that deadline would still be met.

### Architectural

The current structural system of the New Acute Care Hospital is made of moment frames, which offer a considerable amount of freedom for the architecture. If these braces are added to the interior moment frames, they will have an impact on the floor plan. If they are added to the perimeter frames, then the exterior façade will have to be modified. Therefore, an architecture breadth will be included which will detail the impact of the FVD additions as well as propose a solution to that impact.

### Methods

The investigation into Fluid Viscous Dampers will begin by determining the optimal locations for the FVDs in the 6 moment frames. This will need to be accomplished through consulting with faculty members and industry professionals, evaluating architectural criteria, as well as independent research of literature.

After the optimum brace location is determined, an analysis of each FVD brace configuration/location will be compared using a series of ETABs models for each case. A Time-History Analysis will then be undertaken using DBE/MCE values found the geotechnical report. The results from this analysis will be compared across the different damper configurations used, and an optimal configuration will be determined.

Once the damper configuration has been determined, the existing structural system will be reevaluated due to the addition of increased damping. Members will be redesigned accordingly.



## Tasks

### Task 1

Determine the optimum location for FVD braces in each moment frames based on consultation of faculty members and industry professionals, a thorough literature investigation, and the impact of each location on the existing architecture.

### Task 2

Create ETABs models for the 4 different FVD models previously described.

### Task 3

Research the proper methodology for undertaking a Time-History Analysis using ETABs

### Task 4

Perform Time History Analysis to determine Acceleration, Displacements, and Base Shears for each model. Compare the results and select the best configuration based on the criterion previously described.

### Task 5

Determine if addition of braces warrants the redesign of any structural elements.

### Task 6

Architectural Impact Breadth

### Task 7

Cost and Schedule Impact Breadth.

### Task 8

Prepare for Final Presentation

### Task 9

Write paper, making revisions as necessary.

# Timetable

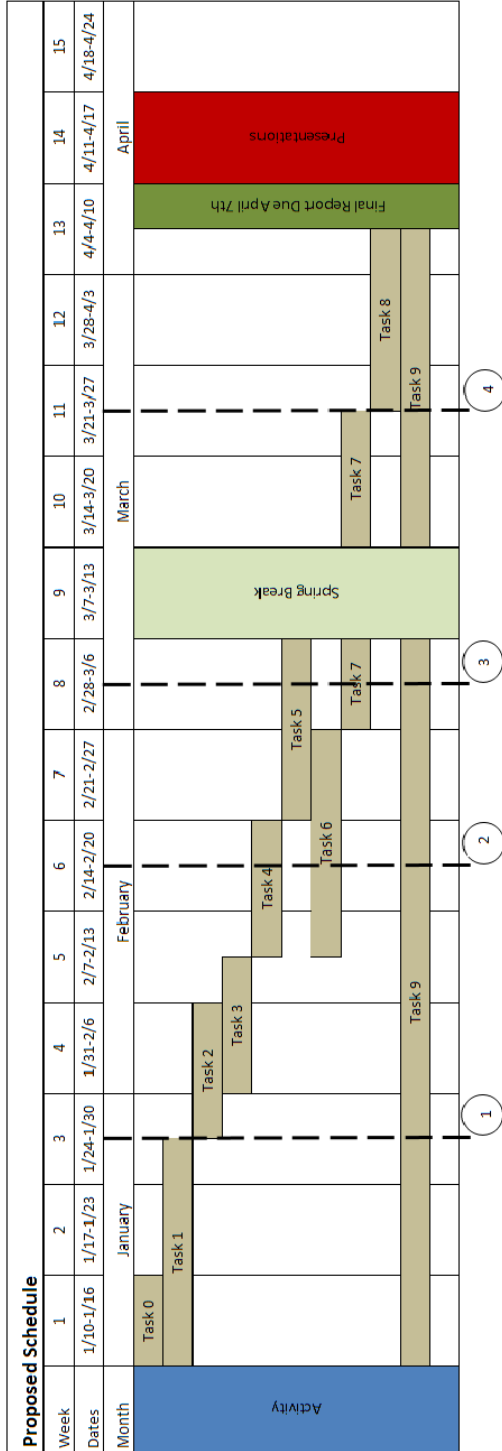

**Task 0:** Revise Proposal and Post to CPEP

**Task 1:** Determine the optimum location for FVD braces in each moment frames based on consultation of faculty members and industry professionals, a thorough literature investigation, and the impact of each location on the existing architecture.

**Task 2:** Create ETABS models for the 4 different FVD models previously described.

**Task 3:** Research the proper methodology for undertaking a Time-History Analysis using ETABS

**Task 4:** Perform Time History Analysis to determine Acceleration, Displacements, and Base Shears for each model. Compare the results and select the best configuration based on the criterion previously described.

**Task 5:** Determine if addition of braces warrants the redesign of any structural elements.

**Task 6:** Architectural Impact Breadth

**Task 7:** Cost and Schedule Impact Breadth

**Task 8:** Prepare for Final Presentation

**Task 9:** Write Paper, making revisions as necessary

**Milestone Activity List**

**Milestone #1 - 1/29/2010 -** Determine FVD location in structure

**Milestone #2 - 2/17/2010 -** Complete Time History Analysis of 4 models  
- Determine Architectural Impact of FVDs

**Milestone #3 - 3/5/2010 -** Complete research cost impact of selected FVD system

**Milestone #4 - 3/24/2010 -** Complete Cost and Schedule Impact Breadth

## Conclusions

An in-depth investigation will be undertaken into the use of Fluid Viscous Dampers to absorb and dissipate the large lateral forces generated during a major seismic event. Four configurations, diagonal braces, concentrically braced chevrons with dampers on diagonals, concentrically braced chevrons with horizontal dampers, and a toggle brace damper system. Once the best damper configuration has been selected, the existing lateral system will be redesigned using smaller section sizes where appropriate.

In addition, two non-structural breadths (cost/schedule impact and architectural impact) will be included.

## **APPENDIX**

## Appendix A: References

Gilani, A. S., Miyamoto, H. K., & Kohagura, T. (2006). Seismic Rehabilitation of a Nine-Story Hospital Building Using Fluid Viscous Dampers. *Structures* .

McNamara, R. J., & Taylor, D. P. (2003). Fluid Viscous Dampers for High-Rise Buildings. *The Structural Design of Tall and Special Buildings* . Wiley InterScience.

Miyamoto, H. K., & Scholl, R. E. (1998, November). Steel Pyramid. *Modern Steel Construction* .

Taylor, D., & Duflo, P. (n.d.). Fluid Viscous Dampers Used for Seismic Energy Dissipation in Structures.